

# GREENLAB

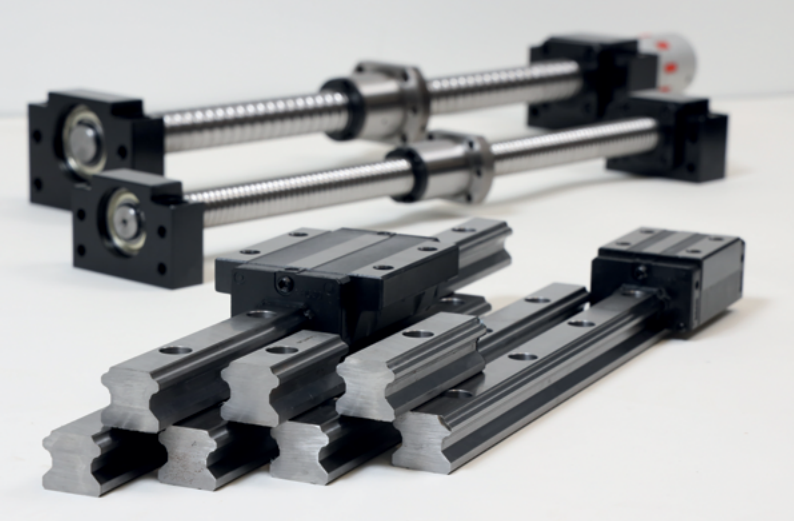
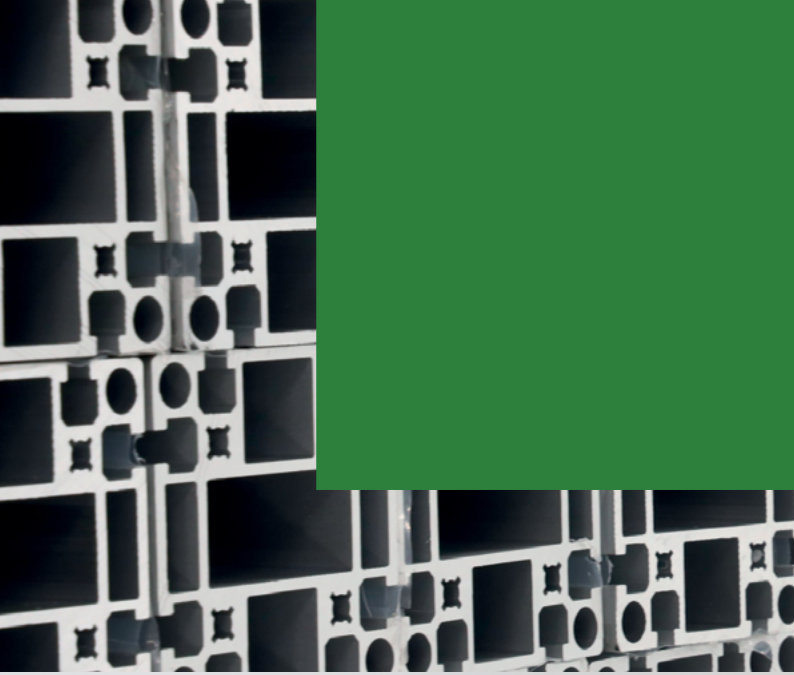

Quality,  
affordability,  
speed – we deliver

# GreenLab aluminium profile and linear system

The GreenLab system includes a wide range of different aluminium profiles and complementary products, linears, ball screws and other components for industrial automation. The system components can be purchased as such, or cut-to-size, processed and machined according to your needs. The aluminium profiles', ball screws' and linear guides' price per meter is the same when sold cut to size or in poles. This versatile system is suitable for all industries, its applications are endless and it makes machine building easy and fast. You will find the product catalogue and pricelist on our website.

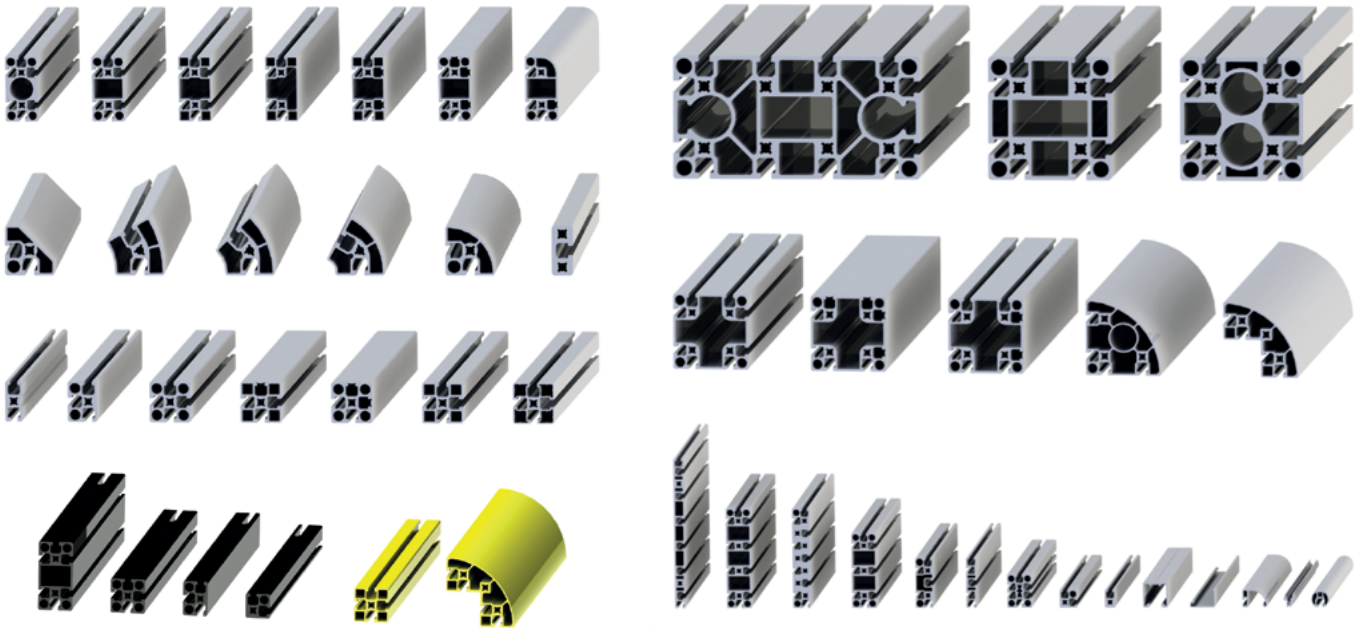

## Profit from the outstanding features of the GreenLab system!

- The newest and most affordable system on the market
- Compatible with many other profile and linear systems
- Products directly from the manufacturer – no intermediaries
- Massive stock, fast deliveries
- High-quality and durable
- Fast mounting and assembly of components
- Uniform grooves in all profiles
- Flexible and environmentally friendly

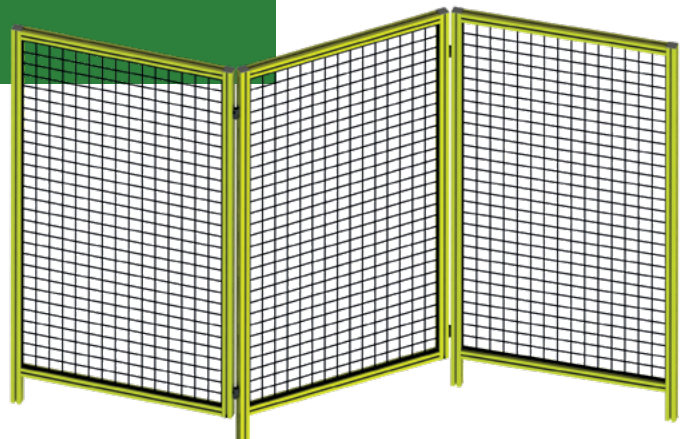
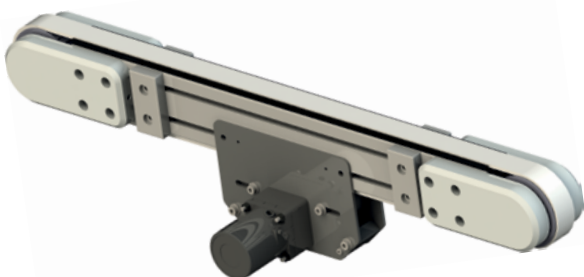

## Customer-specific aluminium profiles made to order

In addition to the complete GreenLab system, we manufacture customer-specific aluminium profiles made to order. If the type of profile required cannot be found among GreenLab products, we will help you with the design, provide you with a mold drawing and give you a quotation on the needed profile in no time. We can offer you any desired aluminium profile for any industrial branch needed. They can be anodized or painted with different gloss levels. We deliver even small quantities cost-effectively. Contact us and let us design together the exact profile you need. Come visit us and learn about our new profile outlet!

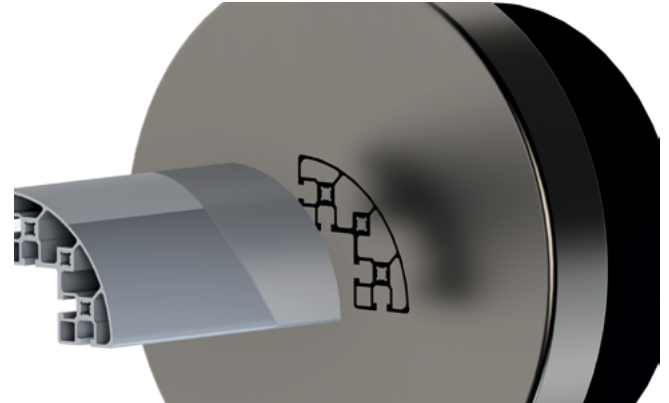
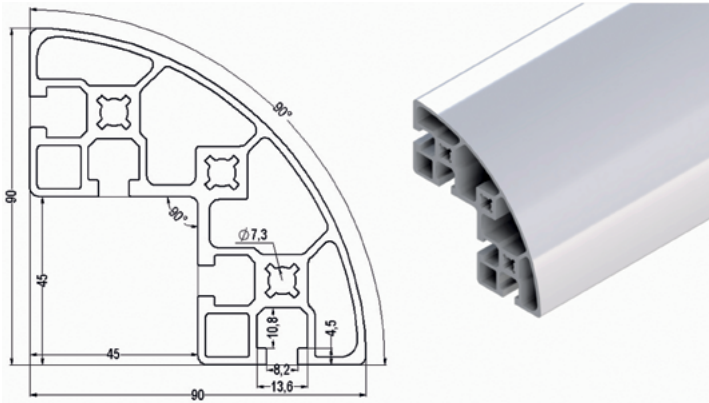

## Industrial automation

We also design and build mechanical constructions and ready GreenLab production automation solutions based on our system components. Applications range from belt-driven and ball screw driven linears to XYZ manipulators, from trolleys to safety guards, from testing equipment, machine frames and conveyors to complex linear and automation systems. All ready solutions are manufactured according to our customers' needs.

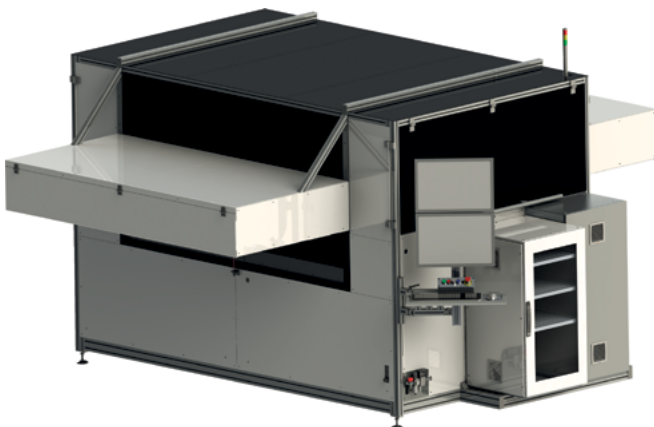

## The way we do it

We provide you with excellent service and guidance for the efficient implementation of the GreenLab system. Our experts have over 25 years of experience in machine building and a vast network of partners offering you the best benefits and solutions. All our GreenLab components are stored and solutions are built in Salo, Finland. Most products in our catalogue can be delivered directly from the stock without delay. Even large component orders are processed and shipped fast without compromising quality. We provide our customers and partners added value through cost-effective and innovative production automation. Come visit us and we will show you what our Greenlab system is all about!



# ***GREENLAB***

## **GreenLab Finland Oy**

Urheilutie 4

25130 Muurla

Finland

+358 (0)44 5502283

info@GreenLab.fi

VAT number FI26308839

www.GreenLab.fi

